

CONTENTS

A **SECTION A**
Contents..... Page 1
Granite Colors..... Page 2-4
Glossary Of Memorial Terms..... Page 5-8
Sandblasting Techniques..... Page 9
Font Styles..... Page 10
Fonts And Design Recommendations Page..... Page 11-12
Production Options Page..... Page 13-15
Memorial Design With Interchangeable Elements..... Page 16-17
Design Samples..... Page 18

B **SECTION B**
BCMN Custom Designs..... Page 1-12
BCMN Angel Designs..... Page 13-15
Cross Memorials..... Page 18-19
Greek Memorials..... Page 20-22
Jewish Memorials..... Page 23-24

C **SECTION C**
Benches..... Page 1-4
Cremation Memorials..... Page 5-9

D **SECTION D**
Hand Etched Memorials..... Page 1
Creating An Etching Scene..... Page 2-3
Etched Memorials..... Page 4-8
Portrait Etchings..... Page 9-10
Etched Inserts..... Page 11-12

E **SECTION E**
Feature Designs And Proposals..... Page 1-10
Columbariums..... Page 11
Mausoleums..... Page 12
Natural Memorials..... Page 13

F **SECTION F**
Standard Monuments..... Page 1-3
Companion Markers..... Page 4-5
Adult Single Markers..... Page 6-10
Infant Markers..... Page 11-12
Bevel Edge Flush Markers..... Page 13
Vase Markers..... Page 14

G **SECTION G**
Pet Memorials..... Page 1-3

DOMESTIC



COLONIAL ROSE



CORAL PINK



DAKOTA



FRENCH CREEK

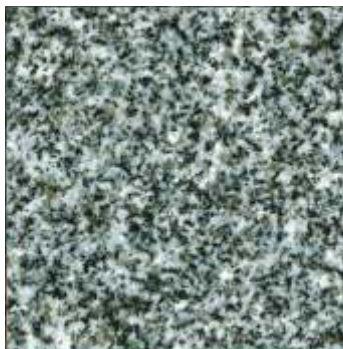

BARRE GRAY



MISSOURI RED



NORTH AMERICAN PINK



STERLING GRAY



WAUSAU RED

Other granites are available. This is a color photo representation of the granite. The actual granite may vary slightly in color.

OVERSEAS



ANXI PINK



BLACK GALAXY



BLACK



BLUE PEARL

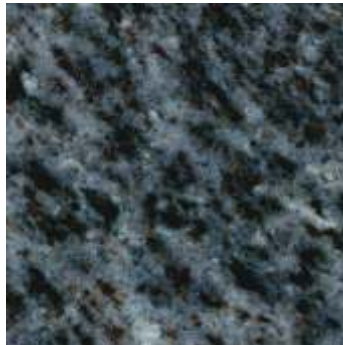

BLUE SILK



CATS EYE BROWN

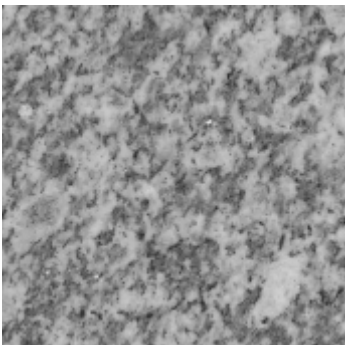

CHINA GRAY



CHINA ST



COFFEE BROWN

Other granites are available. This is a color photo representation of the granite. The actual granite may vary slightly in color.

OVERSEAS

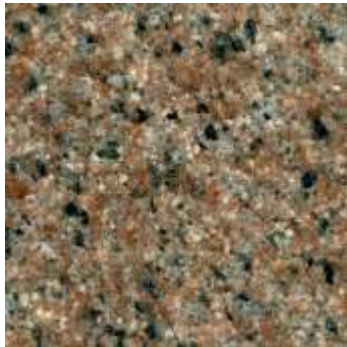

IMPERIAL PINK

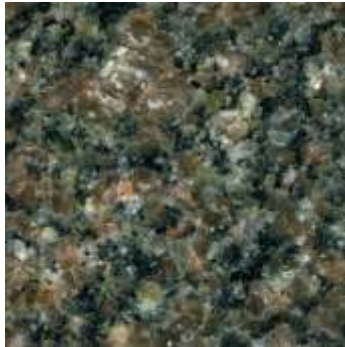

INDIA MAHOGANY

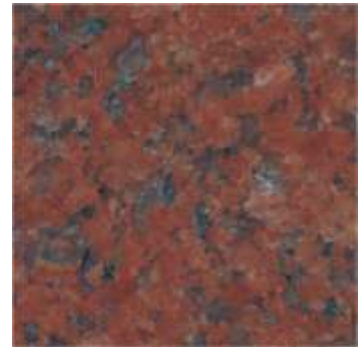

INDIA RED

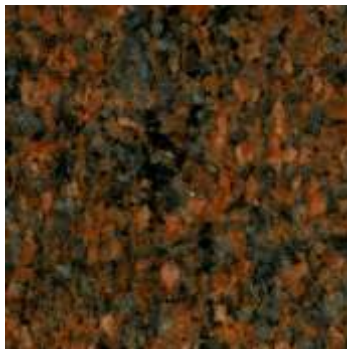

MULTICOLOR RED

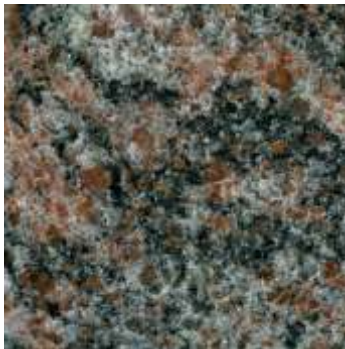

PARADISO



SILVER PEARL



TROPICAL GREEN



TAJ AURORA



BC MAHAGONY

Other granites are available. This is a color photo representation of the granite. The actual granite may vary slightly in color.

READING AND WRITING SIZES

SIZES ARE ALWAYS WRITTEN AS LENGTH x WIDTH x HEIGHT

THE X STANDS FOR THE WORD BY

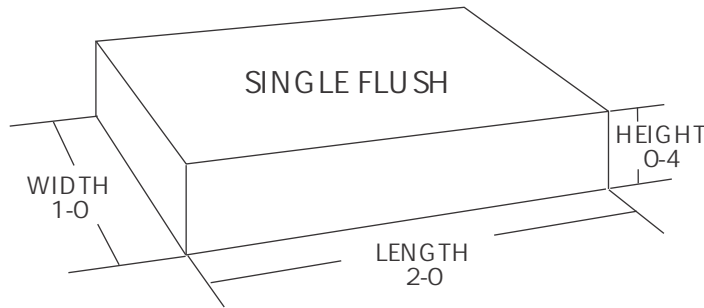

LENGTH - 24" WRITTEN AS 2-0
 WIDTH - 12" WRITTEN AS 1-0
 HEIGHT - 4" WRITTEN AS 0-4

**THIS IS A: 2-0X1-0X0-4
 SINGLE FLUSH MARKER**

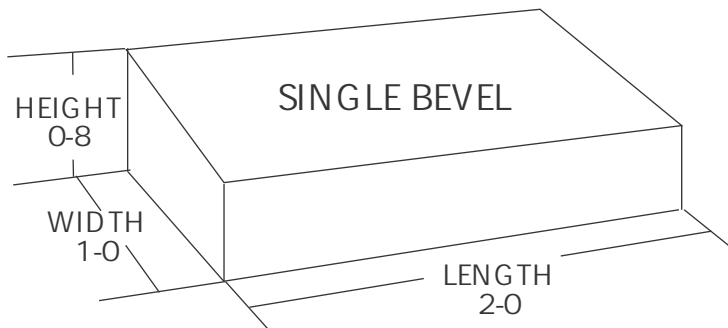

LENGTH - 24" WRITTEN AS 2-0
 WIDTH - 12" WRITTEN AS 1-0
 HEIGHT - 8" WRITTEN AS 0-8

**THIS IS A: 2-0X1-0X0-8
 SINGLE BEVEL MARKER**

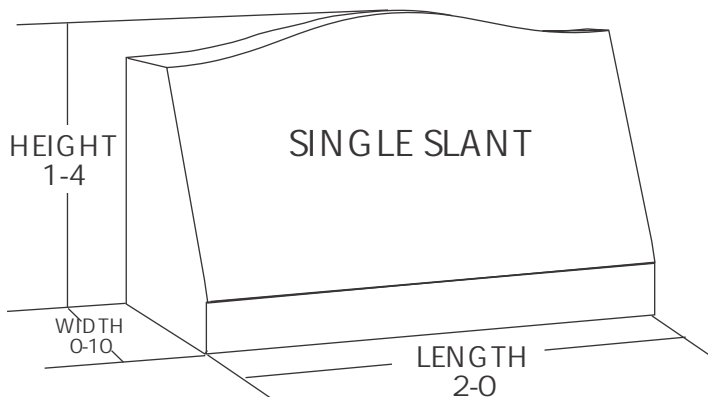

LENGTH - 24" WRITTEN AS 2-0
 WIDTH - 10" WRITTEN AS 0-10
 HEIGHT - 16" WRITTEN AS 1-4

**THIS IS A: 2-0X0-10X1-4
 SINGLE SLANT MARKER**

REFERENCE FOR SIZES

2" = 0-2	14" = 1-2	26" = 2-2	38" = 3-2	50" = 4-2
4" = 0-4	16" = 1-4	28" = 2-4	40" = 3-4	52" = 4-4
6" = 0-6	18" = 1-6	30" = 2-6	42" = 3-6	54" = 4-6
8" = 0-8	20" = 1-8	32" = 2-8	44" = 3-8	56" = 4-8
10" = 0-10	22" = 1-10	34" = 2-10	46" = 3-10	58" = 4-10
12" = 1-0	24" = 2-0	36" = 3-0	48" = 4-0	60" = 5-0

READING AND WRITING SIZES

SIZES ARE ALWAYS WRITTEN AS LENGTH x WIDTH x HEIGHT

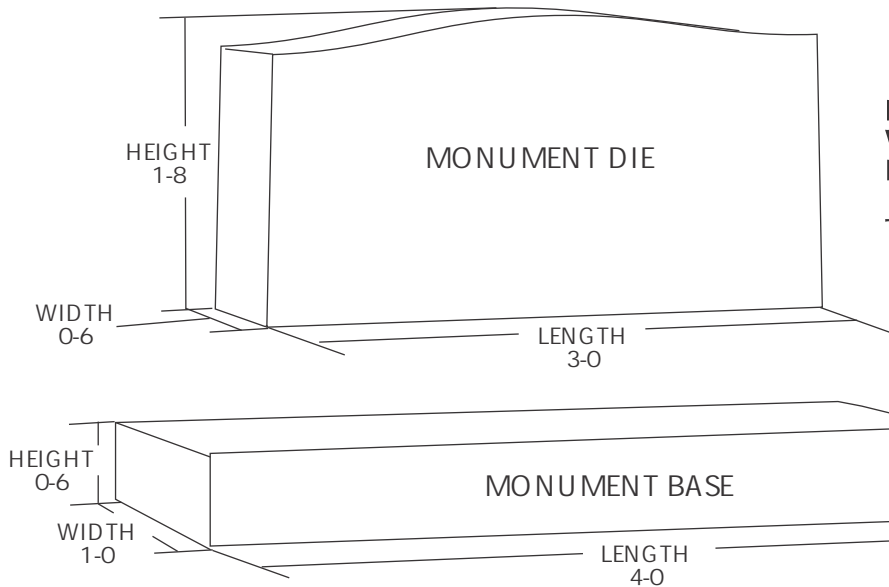

LENGTH - 36" WRITTEN AS 3-0
 WIDTH - 6" WRITTEN AS 0-6
 HEIGHT - 20" WRITTEN AS 1-8

THIS IS A: **3-0X0-6X1-8**
MONUMENT DIE

LENGTH - 48" WRITTEN AS 4-0
 WIDTH - 12" WRITTEN AS 1-0
 HEIGHT - 6" WRITTEN AS 0-6

THIS IS A: **4-0X1-0X0-6**
MONUMENT BASE

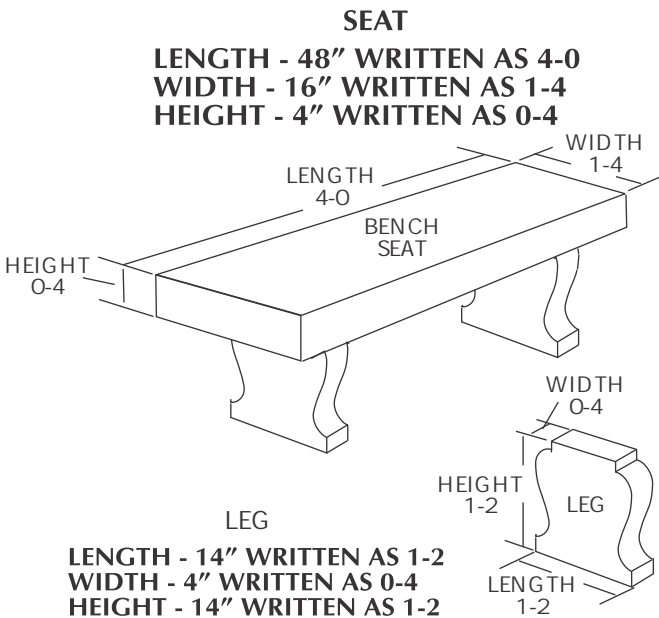

SEAT
 LENGTH - 48" WRITTEN AS 4-0
 WIDTH - 16" WRITTEN AS 1-4
 HEIGHT - 4" WRITTEN AS 0-4

LEG
 LENGTH - 14" WRITTEN AS 1-2
 WIDTH - 4" WRITTEN AS 0-4
 HEIGHT - 14" WRITTEN AS 1-2

THIS IS A BENCH: **SEAT 4-0X1-4X0-4**
LEGS 1-2X0-4X1-2

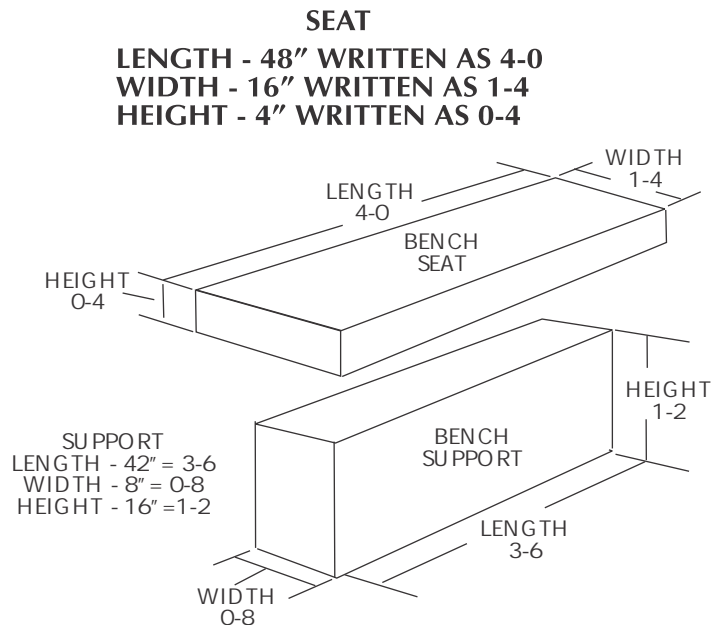

SEAT
 LENGTH - 48" WRITTEN AS 4-0
 WIDTH - 16" WRITTEN AS 1-4
 HEIGHT - 4" WRITTEN AS 0-4

SUPPORT
 LENGTH - 42" = 3-6
 WIDTH - 8" = 0-8
 HEIGHT - 16" = 1-2

THIS IS A BENCH: **SEAT 4-0X1-4X0-4**
SUPPORT 3-6X0-8X1-2

REFERENCE FOR SIZES

62" = 5-2	74" = 6-2	86" = 7-2	98" = 8-2	110" = 9-2
64" = 5-4	76" = 6-4	88" = 7-4	100" = 8-4	112" = 9-4
66" = 5-6	78" = 6-6	90" = 7-6	102" = 8-6	114" = 9-6
68" = 5-8	80" = 6-8	92" = 7-8	104" = 8-8	116" = 9-8
70" = 5-10	82" = 6-10	94" = 7-10	106" = 8-10	118" = 9-10
72" = 6-0	84" = 7-0	96" = 8-0	108" = 9-0	120" = 10-0

STONE TREATMENTS/FINISHES

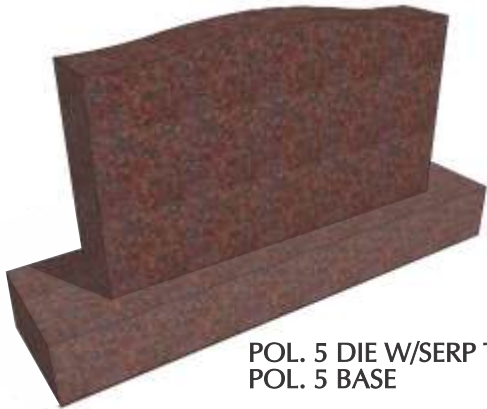

POL. 5 DIE W/SERP TOP
POL. 5 BASE

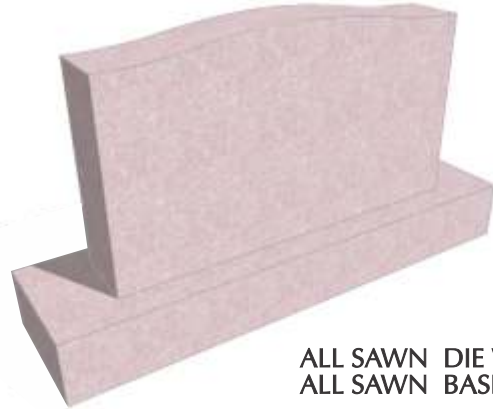

ALL SAWN DIE W/SERP TOP
ALL SAWN BASE

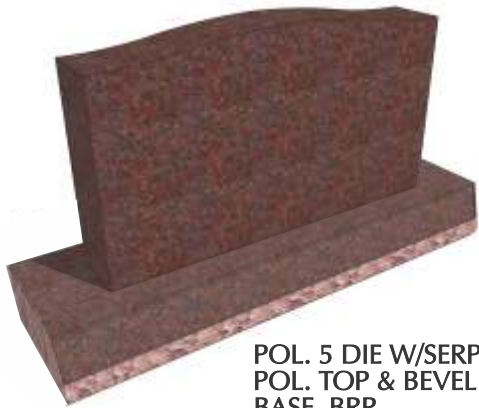

POL. 5 DIE W/SERP TOP
POL. TOP & BEVEL FRONT
BASE, BRP

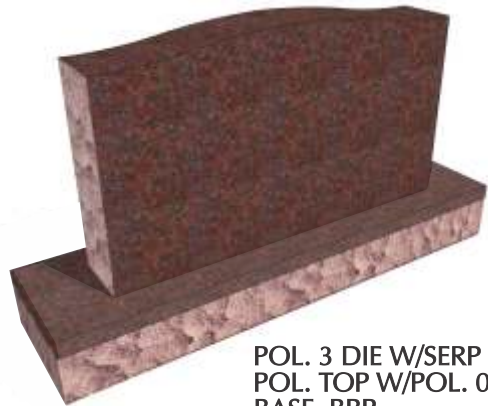

POL. 3 DIE W/SERP TOP, BRP
POL. TOP W/POL. 0-2 MARGIN
BASE, BRP

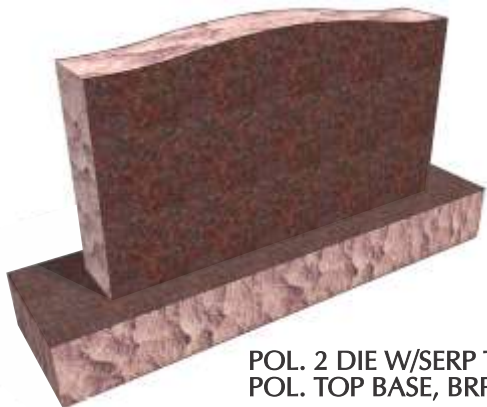

POL. 2 DIE W/SERP TOP, BRP
POL. TOP BASE, BRP

COMMON MONUMENT STYLES

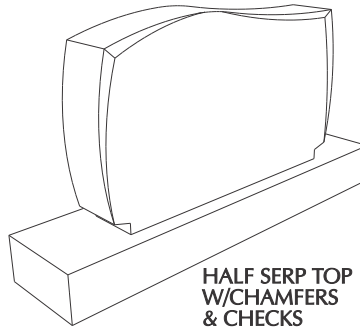

HALF SERP TOP
W/CHAMFERS
& CHECKS

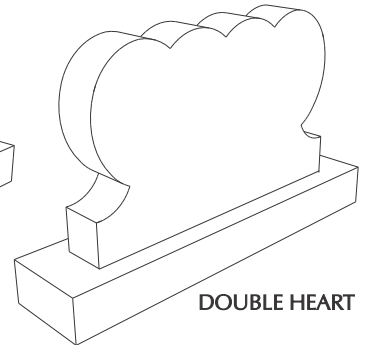

DOUBLE HEART

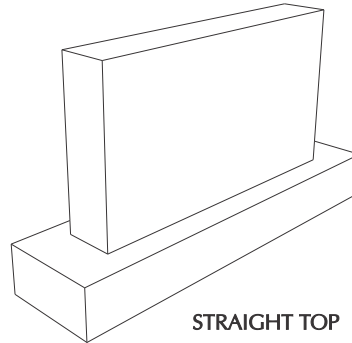

STRAIGHT TOP

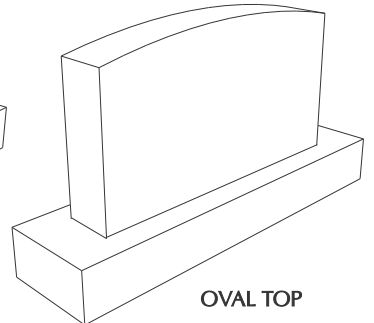

OVAL TOP

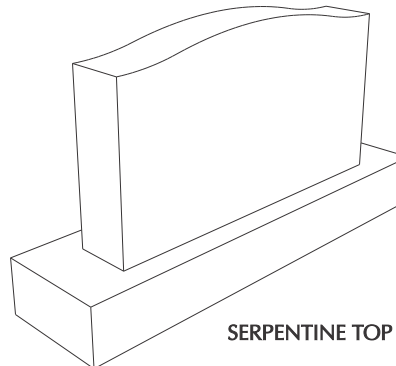

SERPENTINE TOP

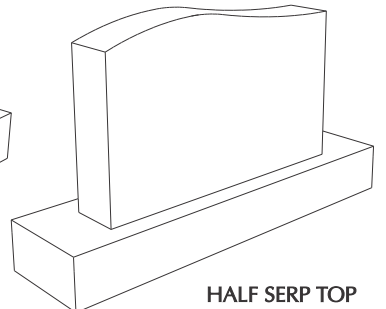

HALF SERP TOP

MEMORIAL TERMS ILLUSTRATED

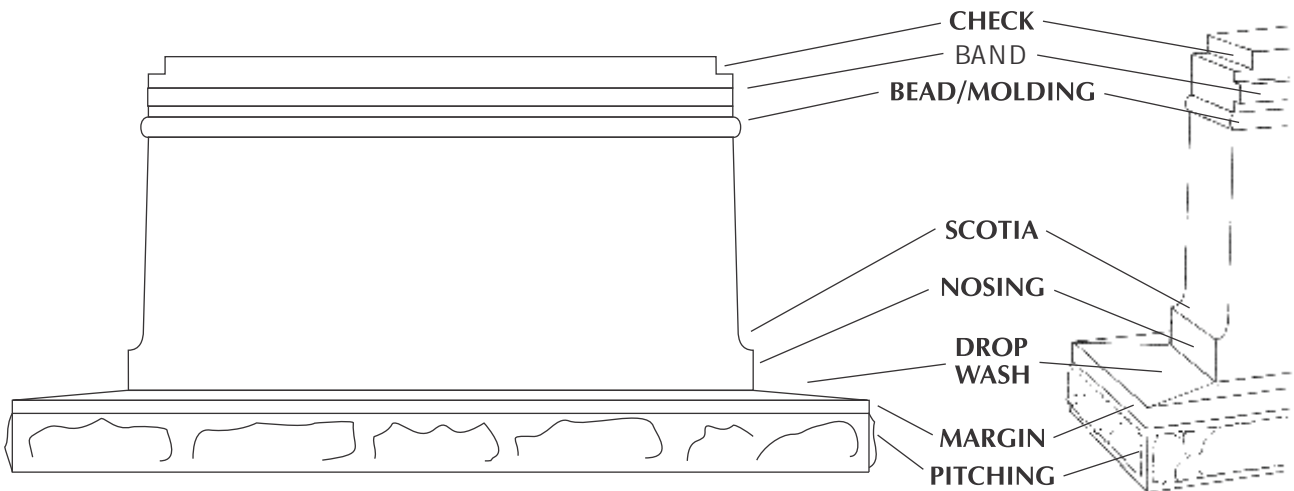
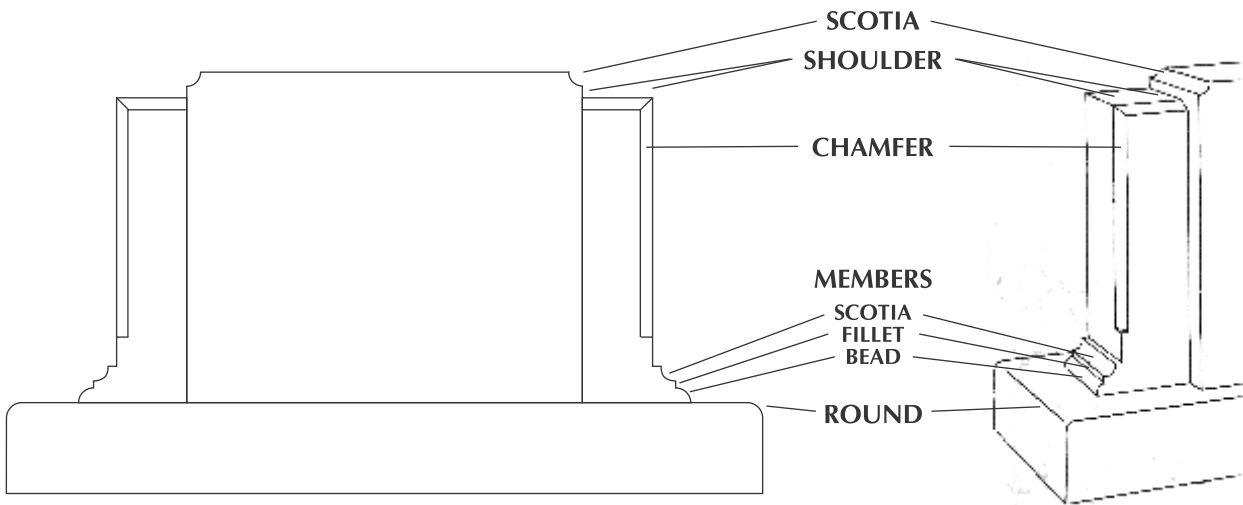
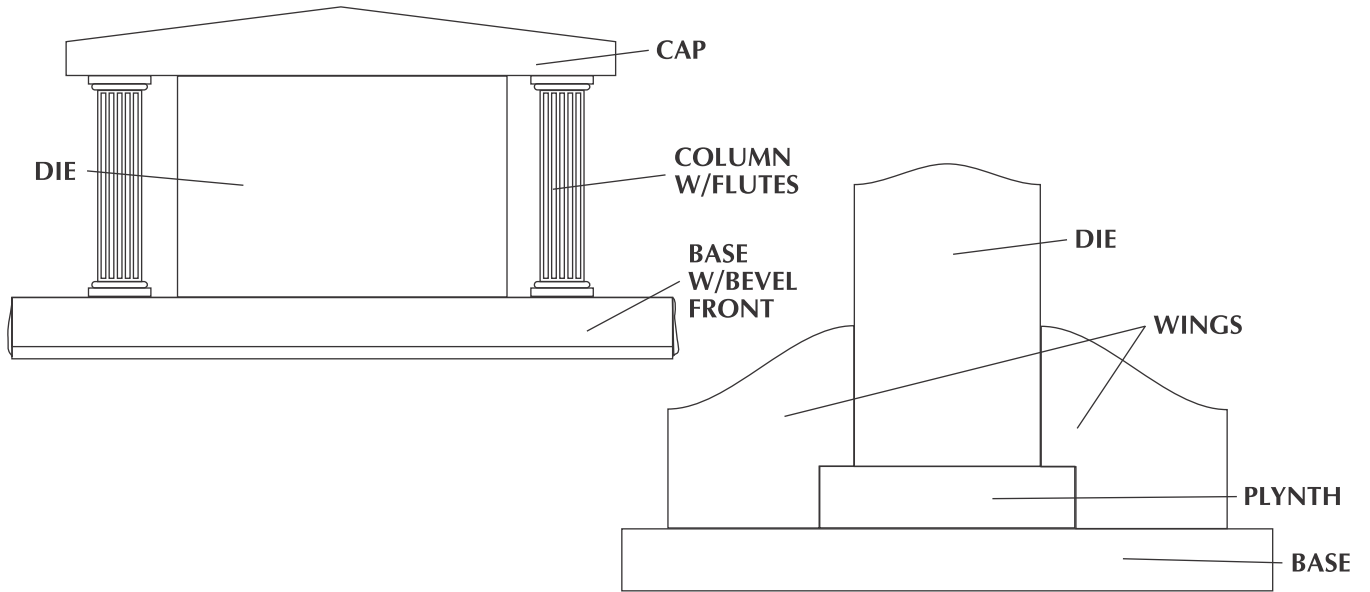



Square Raised

Round Raised



These font styles are recommended.

OPTIMA
ROMAN
ROMAN CONDENSED
GOUDY
GOVERNMENT

TIMES ROMAN
BANGKOK
FRITZ
BUKNIST
PEIGNOT

THESE FONTS ARE SOME OF OUR MOST POPULAR FOR GENERAL LETTERING OF FAMILY NAMES AND INDIVIDUAL INFORMATION.

Murray Hill
Lincoln
Zurich

Commercial Script
Brush Script
Caslon Swash

THESE STYLIZED FONTS WORK WELL FOR A FAMILY NAME. WE ARE LIMITED AS TO HOW SMALL WE CAN PRODUCE THEM IN SANDBLAST.

RC GOTHIC
VERMARCO
HELVETICA

OPTIMA BOLD
BLACKLIGHT
UNIVERSITY

THESE FONTS ARE A UNIFORM THICKNESS WHICH ALLOW US TO SANDBLAST THEM AT A SMALLER SIZE.

The intent of this guide is to help simplify the process of design layout and font selection. Determining the design that best represents your client's legacy is critical. Please consider allowing our team of designers the freedom to select font size, allowing you more time to focus on the specific design elements that represent the life being memorialized. Our staff is committed to providing a design that blends the elements chosen with our knowledge of memorialization to create the best lasting tribute.

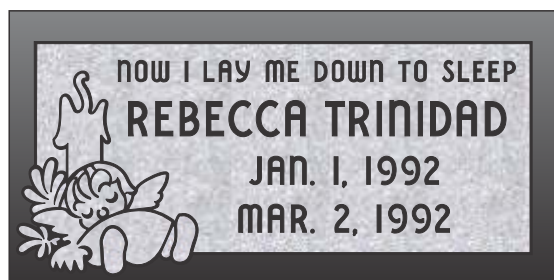

BCMN196

INFANT MARKERS

Infant markers are limited by the amount of space available for design and lettering. BCMN196 is an example of a well balanced layout. Vermarco is the most recommended font choice, while additional options include RC Gothic and University. Brush Script can be used for small verse or title applications.

PLEASE NOTE: The examples shown in the catalog and on our website are an excellent resource for visual perspective. When design challenges present themselves, please know our team of designers are ready to assist you with solutions.



BCMN192



BCMN180



BCMN159

ADULT SINGLE MARKERS

The above samples represent options of lettering and designs that can be applied when designing single markers. Any adult single marker design shown within the catalog or website can be used in creating a flush, bevel or slant memorial. Recommended fonts are Optima, Roman, Fritz and Zurich.

COMPANION MARKERS

The companion flat marker designs shown within this book will also work on companion slants and in many cases upright monuments. Extra design elements can be considered due to additional space. Fonts recommended are Roman, Goudy, Fritz and Optima. We recommend Vermarco or brush script when requesting marriage dateds, maiden names and verses.

STANDARD MONUMENTS AND BCMN DESIGNS

The recommended fonts on our **FONT STYLES SECTION A - PAGE 10** will work well with any **STANDARD MONUMENT** or **BCMN CUSTOM DESIGNS**. There are many more fonts and options available, please contact us about custom fonts and their suitability for unique designs. Keep in mind that our designers are willing to choose a font on your behalf with some simple guidance, such as “use a traditional font” or “contemporary font” or “stylish script”. Simple font styles like Vermarco are always recommended choices when including marriage dates, maiden names, titles and verses.



BCMN 112



BCMN 111



PRODUCTION TECHNIQUE COMPARISON

THESE EXAMPLES SHOW DIFFERENT DESIGN SOLUTIONS BASED ON THE SAME DESIGN INFORMATION

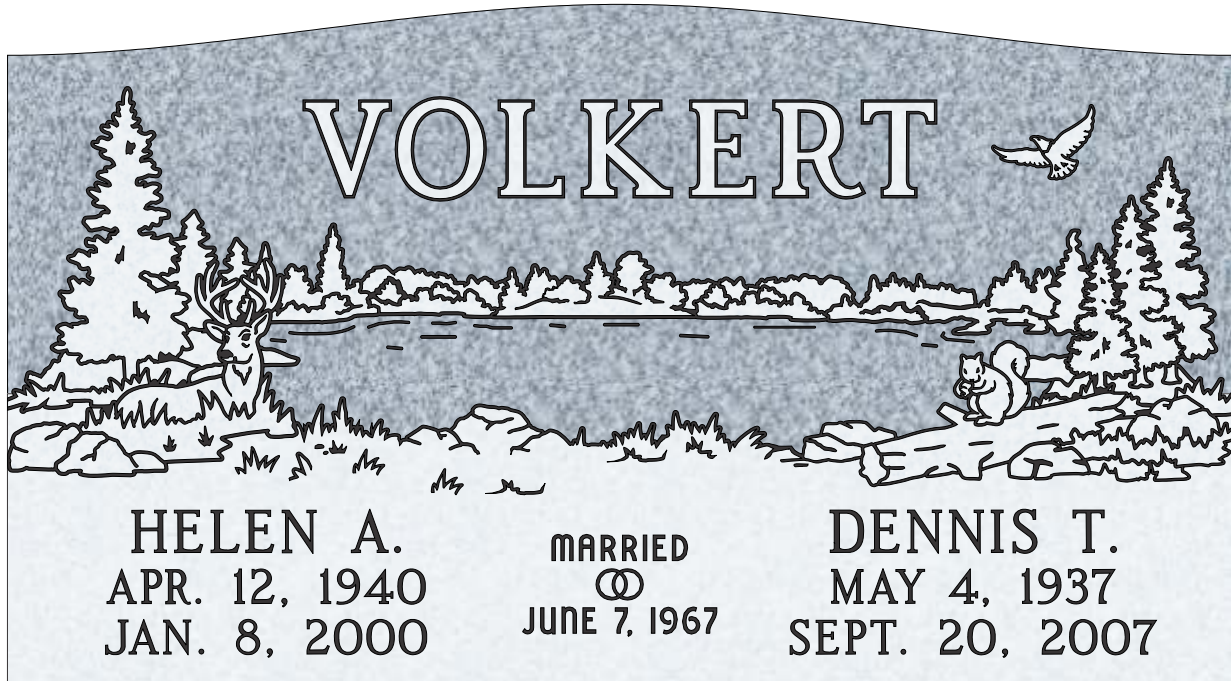

SANDBLAST INCISED

Entire scene is sandblast incised. (See Sandblasting Techniques Page A9)
Can be done on any color granite.
Detail is limited.

BCMN241

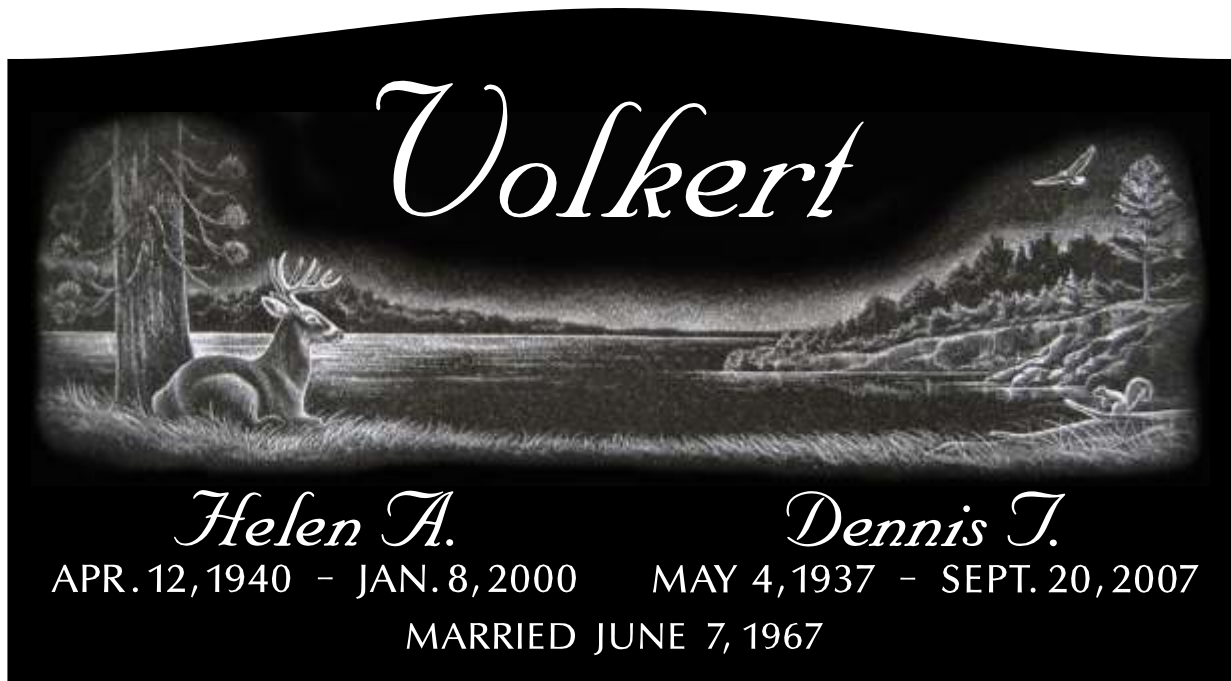

HAND ETCHING

Design is drawn by hand on the stone face with diamond tipped engraving tools. Lettering is Sandblast Incised or Frost. (See Sandblasting Techniques Page A9)
Black granite is preferred.
High detail is possible, provides a more artistic and warm overall look.

TYPICAL DESIGN CARVING OPTIONS AVAILABLE

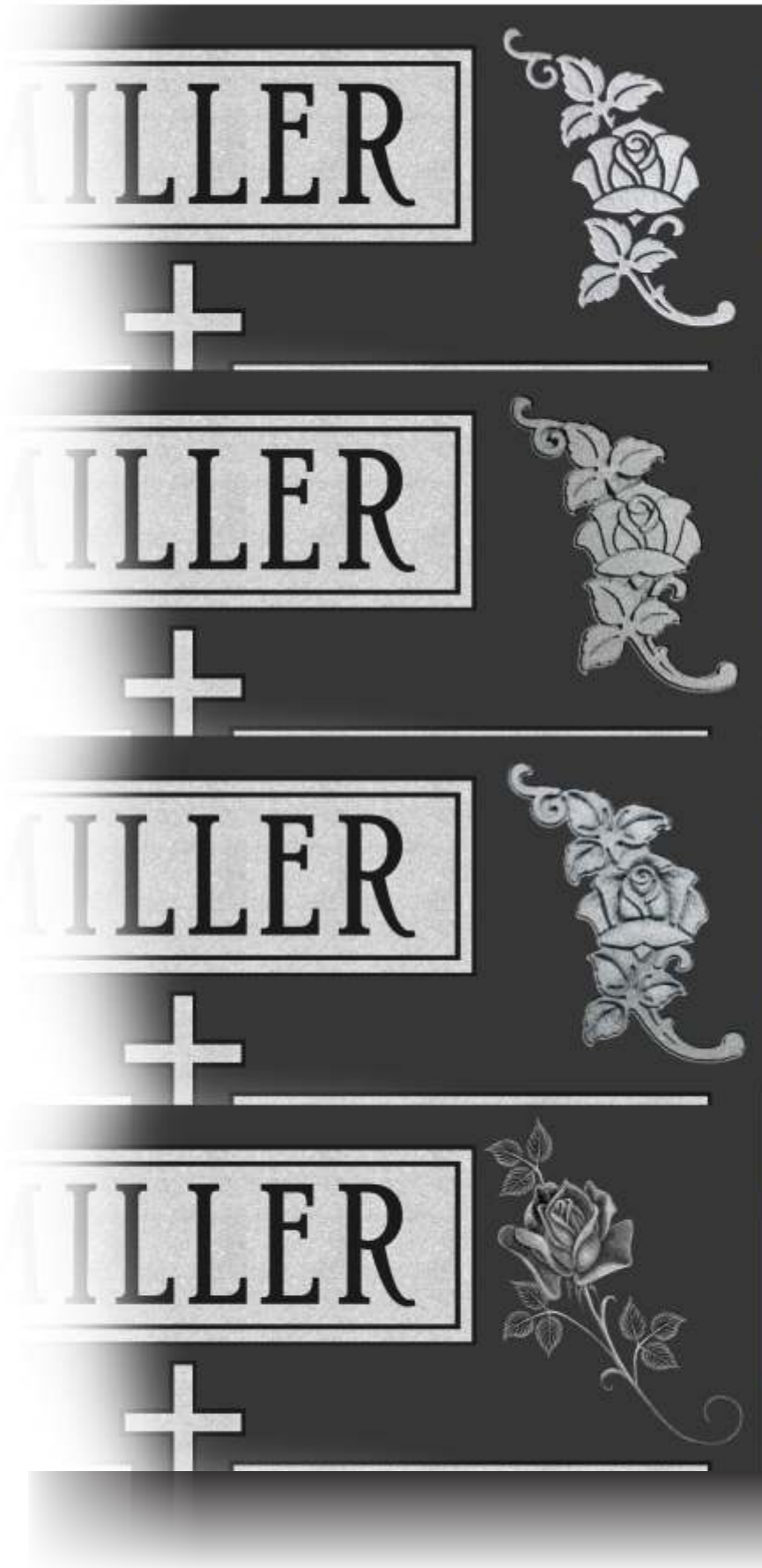

FROST CARVING

Light colored area is frost, no sandblast incised lines.

FLAT CARVING

Light colored area is frost, dark lines are sandblast incised.

SHAPED CARVING

Light colored frost area is sandblasted to produce a sculpted effect. Dark lines are sandblast incised.

HAND ETCHING

Drawn by hand on granite surface with diamond tipped engraving tools. Photo realistic effect.

On the following pages you will find a guide to creating a unique design using individual elements that are available to you.

Access our website to find many more specific elements in the clipart library.

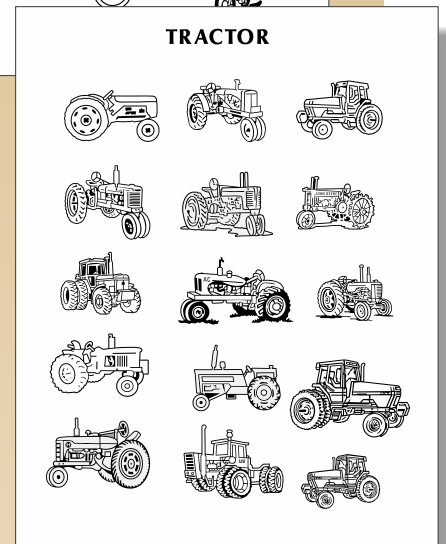
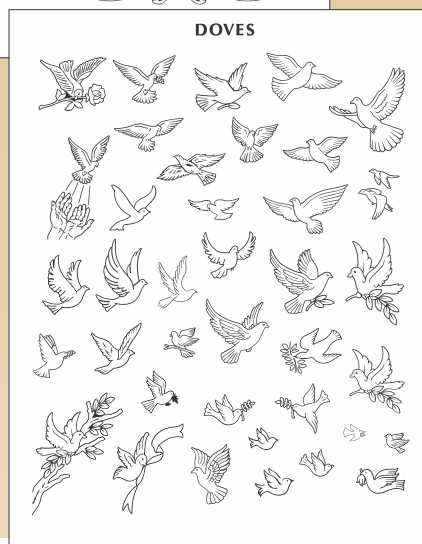
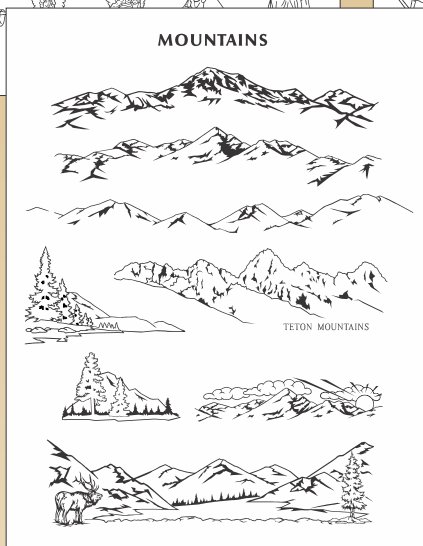
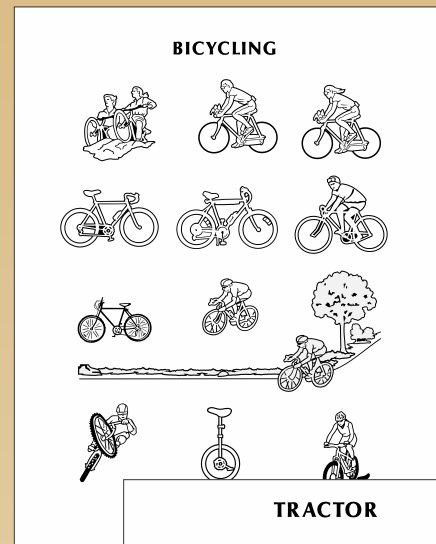
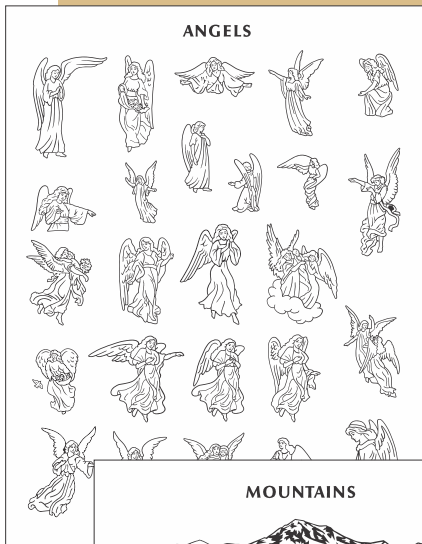

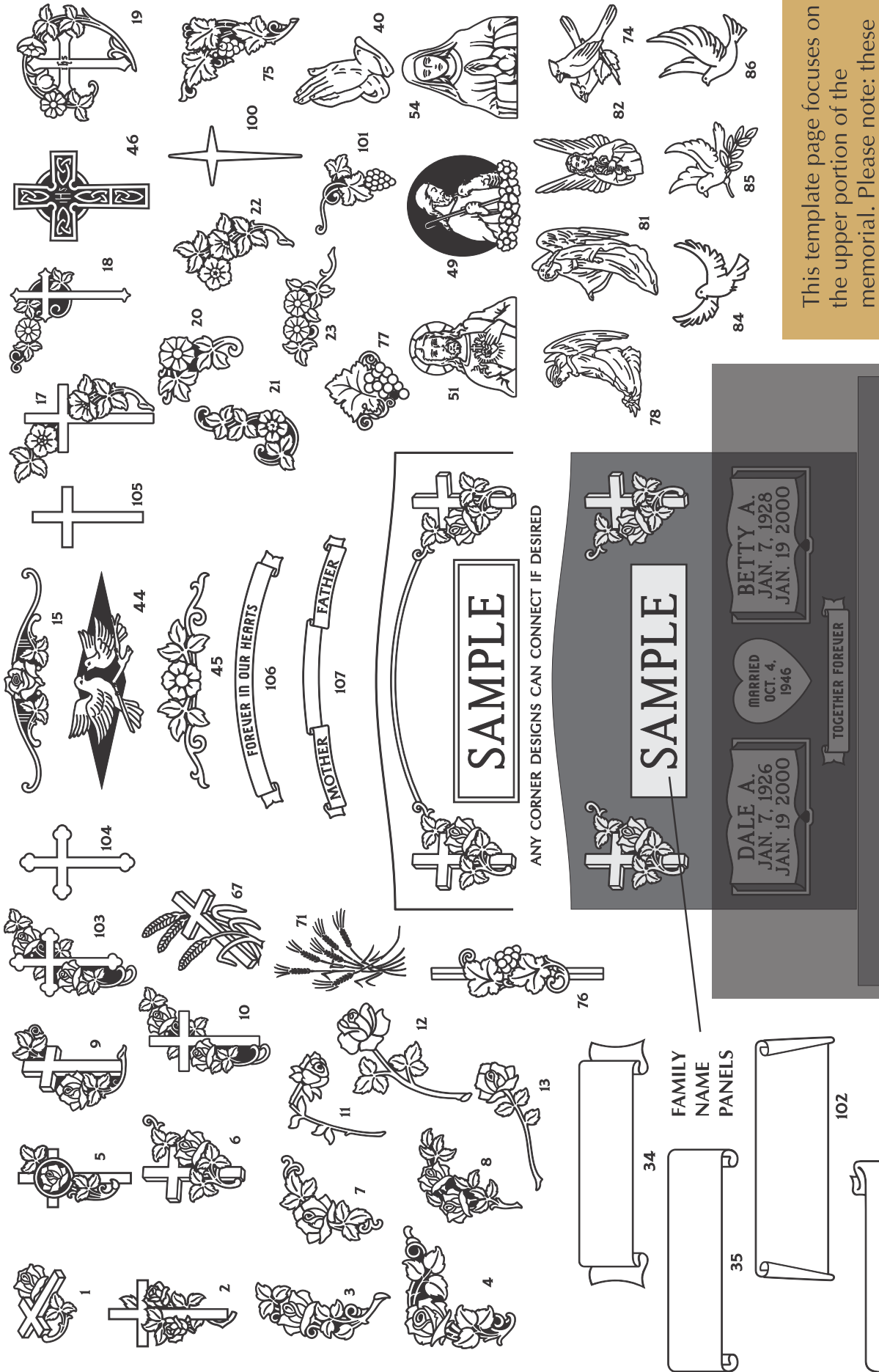

ANY CORNER DESIGNS CAN CONNECT IF DESIRED

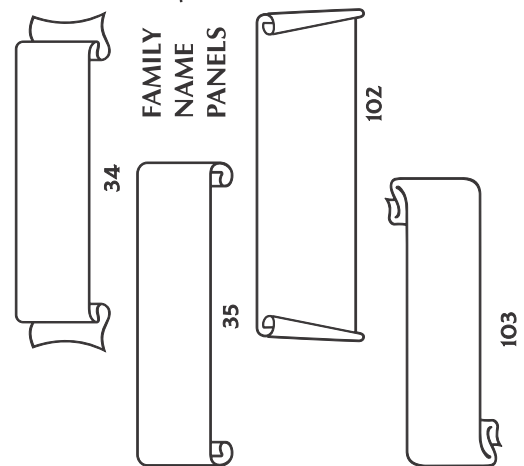

This template page focuses on the upper portion of the memorial. Please note: these elements are interchangeable; but in some cases are limited due to available space.

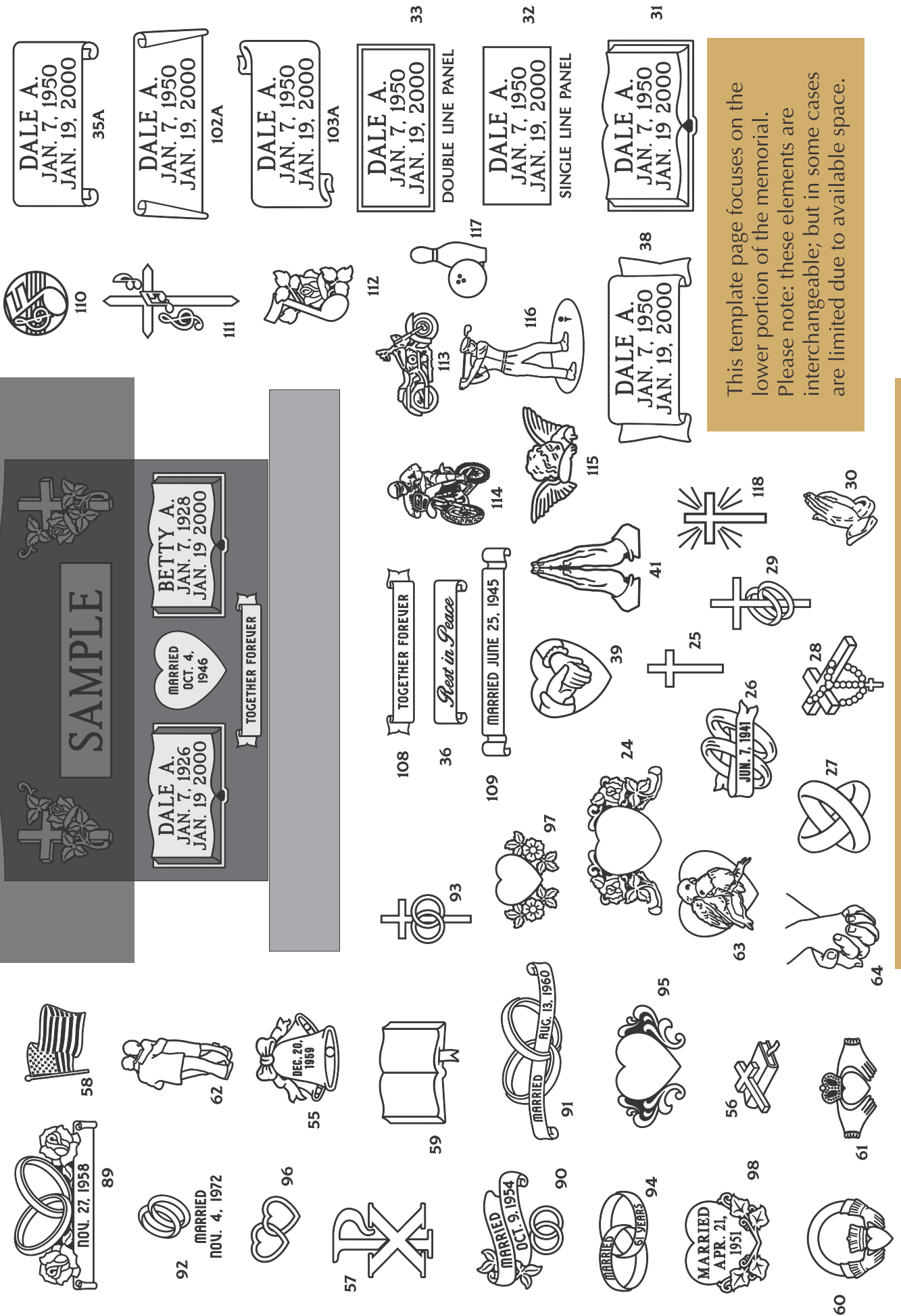
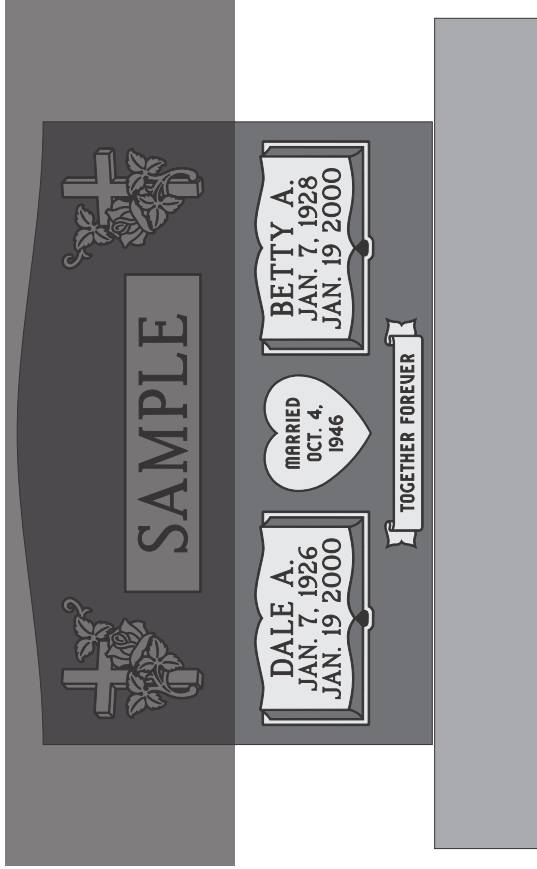

This template page focuses on the lower portion of the memorial. Please note: these elements are interchangeable; but in some cases are limited due to available space.

Please see our website for additional options

MONUMENTS DESIGNED USING INTERCHANGEABLE ELEMETS



BCMN083DEERBORNE

ELEMENTS USED: 103A, 36, 67

FONTS USED: BRUSH SCRIPT, ROMAN, COMMERCIAL SCRIPT

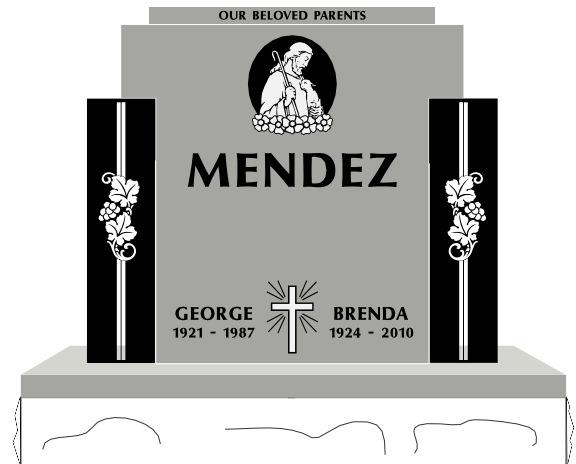

BCMN052MENDEZ

ELEMENTS USED: 118, 76, 49

FONTS USED: OPTIMA



BCMN220CLARKTON

ELEMENTS USED: 44, 29

FONTS USED: FRITZ, ZURICH



BCMN094HANTON

ELEMENTS USED: 19, 97

FONTS USED: FRITZ, VERMARCO

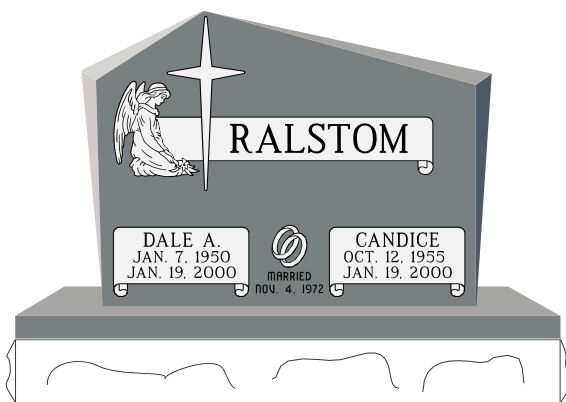

BCMN005RALSTOM

ELEMENTS USED: 100, 78, 92

FONTS USED: ROMAN, VERMARCO

The monument designs shown on this page were designed using only the Interchangeable Elements in Section A pages 16 and 17, the BCMN Custom Designs from Section B, pages 6, 8, 9 and 12 and fonts from Section A page 10. As you can see the design possibilities are almost limitless. This catalog is a tool that can assist in crafting designs that can be unique and personal to each individual customer. The website will provide even more specific content and convenience.